

# **RAPIDrain™**

## **KITCHENWARE DRAINER**

Are your clean kitchenware racks immersed in standing water? Do your clean dishtables not drain properly? then try the first drainer designed specifically for the Food Service industry to eliminate this problem and to compliment the **POWERDry™** kitchenware dryer.

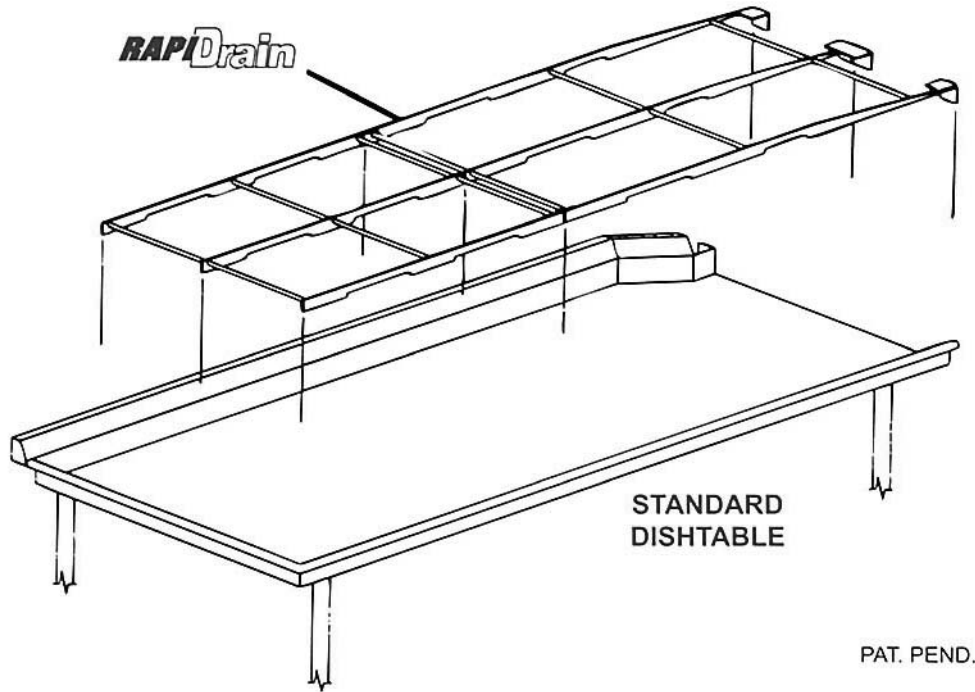

### *Before the* **RAPIDrain™** **Kitchenware Drainer**

- Cross contamination from standing water
- Spotting of dishware due to splash
- Excess water remains trapped in rack
- Base of kitchenware items remain wet

### *After the* **RAPIDrain™** **Kitchenware Drainer**

- Sanitary drying conditioners
- Reduces spotting problems
- Disembogues water
- Dry dishes/trays drain properly

  
**SAN'AIRE**  
**INDUSTRIES**  
*The solution to your  
sanitary drying problems*

*Call our sales department:*

**800-757-1912**  
101 E. Felix Street  
Fort Worth, TX 76115  
817-924-7189  
Fax: 817-921-3963

- Easy placement
- No maintenance required
- Health Departments love them

# RAPIDrain™

## KITCHENWARE DRAINER

### Dimensions (inches/cm)

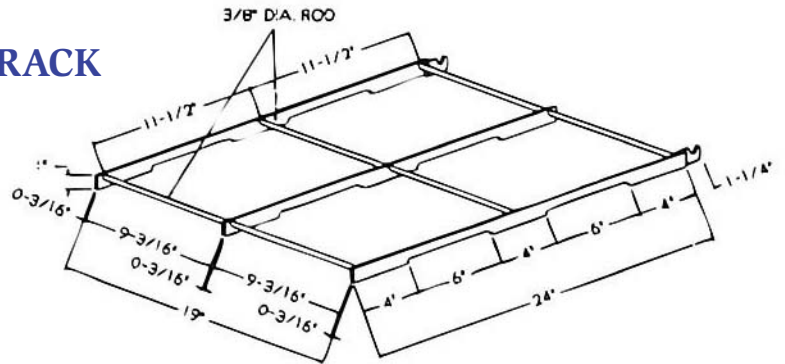
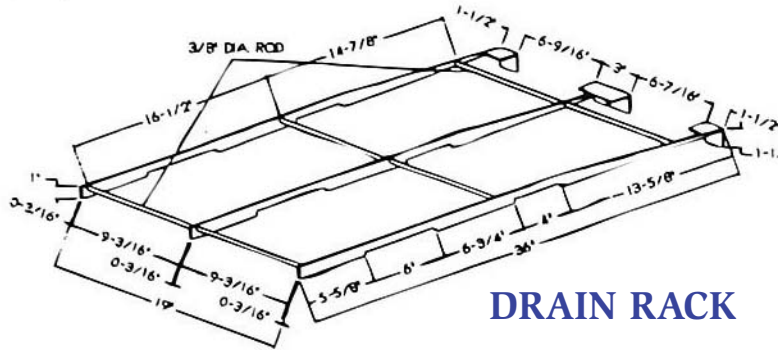

### Bid Specifications

MODEL#	Description	Length	Width	Height	90° Lip	Construction
RD-101	Drainer	36"	19"	1"	1-1/2"	All S/S construction
RD-101E	Extension	24"	19"	1"	N/A	All S/S construction

### Standard Equipment shall include:

- All stainless steel construction:
  - 1" x 3/16" flat bar
  - 3/8" round rod
  - 16 ga. formed ends
- Openings on flat bar for water to flow through
- Rust resistant
- Warranty—One (1) year workmanship

### Options and Accessories

- Custom sizing available.  
Contact factory for pricing
- 3/8" round rod
- 16 ga. formed ends

### Notes:

Due to ongoing analysis programs at SanAire Industries, Inc., specifications are subject to change without notice.

Revised July 2000